

DN40 MAINLINE ONLY

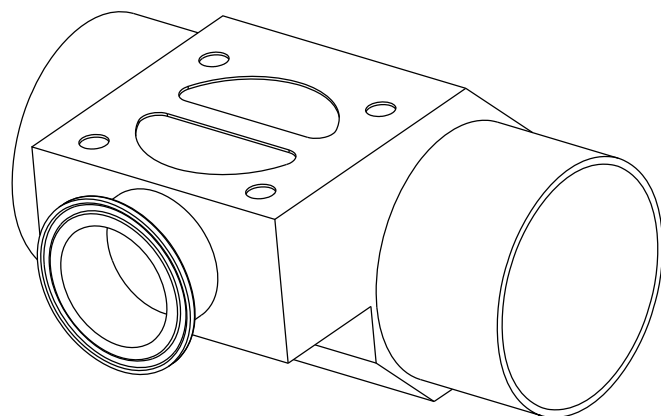

DN65 TO DN100  
MAINLINE ONLY

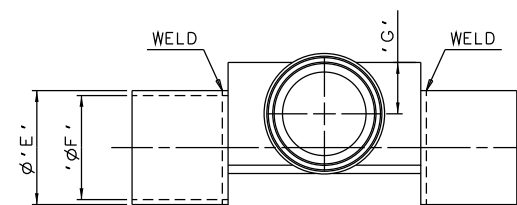
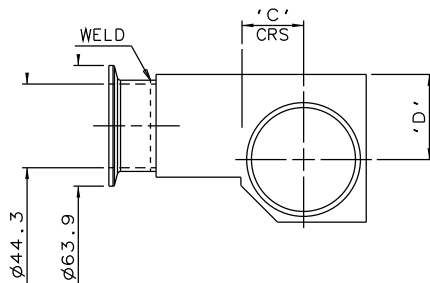
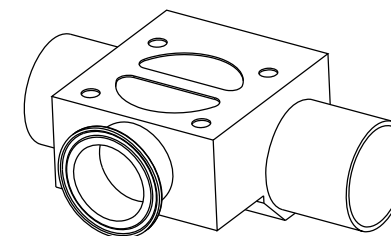
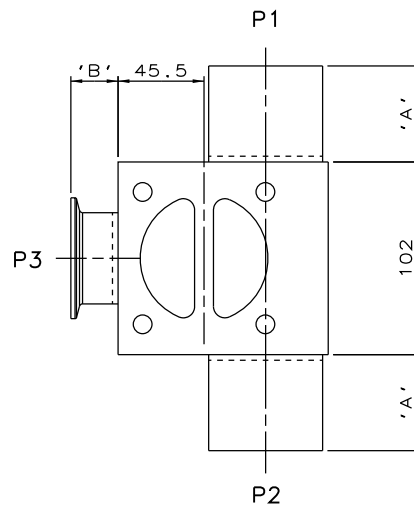

DN50 MAINLINE ONLY

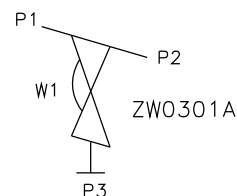

ORIENTATION AS PER  
P&ID DIAGRAM FOR  
OPTIMUM DRAINABILITY.

MAINLINE SIZE	A	B	C	D	$\phi E$	$\phi F$	G	BODY WEIGHT
mm	mm	mm	mm	mm	mm	mm	mm	Kgs
DN40	50.8	25.0	27.2	38.5	48.3	44.3	26.2	3.6
DN50	50.8	25.0	32.6	45.0	60.3	55.1	27.2	3.9
DN65	50.8	25.0	40.5	52.0	76.1	70.9	27.2	3.6
DN80	50.8	25.0	46.9	56.0	88.9	83.7	27.2	4.0
DN100	101.6	25.0	59.6	65.0	114.3	109.1	27.2	5.4

The information on this sheet is Private and Confidential and is the property of Crane Process Flow Technologies Limited and must not be published directly or indirectly in any manner whatsoever without the written permission of the Company and must not be used in any way detrimental to their interests.  
© Crane Process Flow Technologies

**CRANE** Process Flow Technologies  
A Crane Co. Company

**Saunders**  
The Science Inside

Title  
SCHEDULE OF LEADING DIMENSIONS FOR DN40  
WEIR 'T' BODY COMPLETE WITH :  
MAINLINE : ISO 1127 S1 BUTT WELD ENDS  
BRANCH : DN40 HYGIENIC CLAMP END WITH ISO 1127 S1 BORE

Drawn JRD Date 14.10.11

UNCONTROLLED IN  
HARD COPY FORMAT

Checked RND Date 23.03.12

First Angle Projection Method E

Drawing No. WEB-086 Issue. 2

DO NOT SCALE

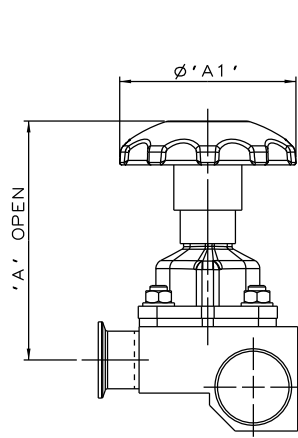

SS NON SEALED  
BONNET ASSEMBLY

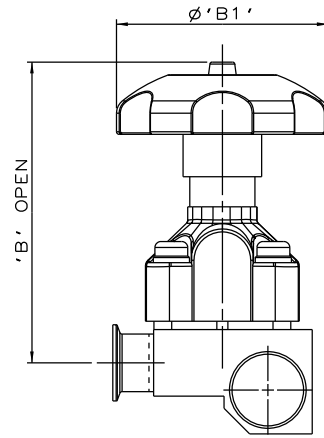

PES BONNET  
ASSEMBLY

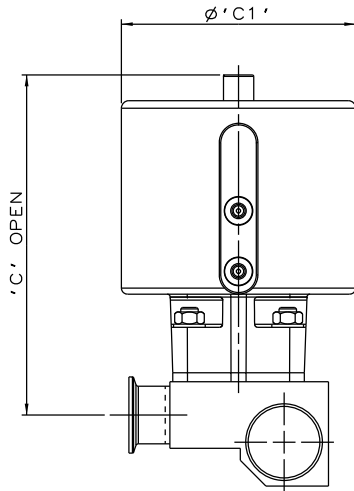

EC ACTUATOR  
(ALL MODES)

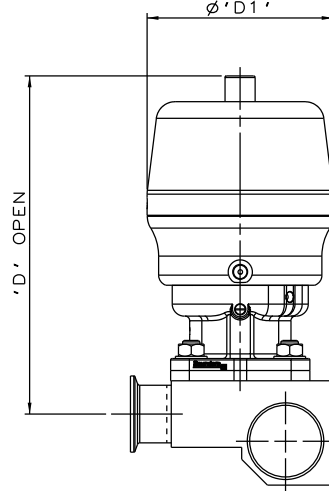

\*S360 ACTUATOR

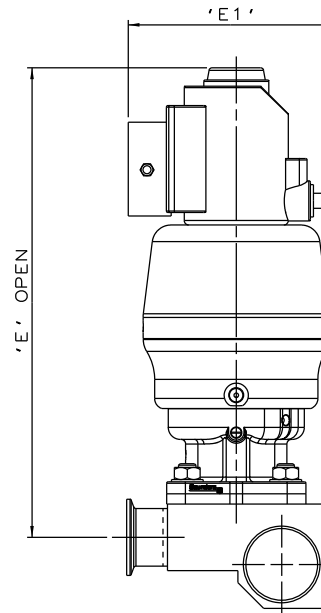

\*S360 ACTUATOR  
WITH I-VUE SENSOR

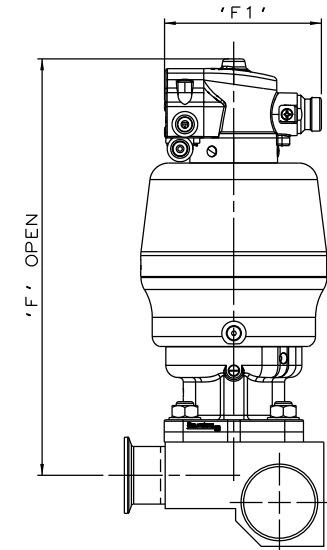

\*S360 ACTUATOR  
WITH M-VUE SENSOR

\*DIMENSIONS SHOW MAXIMUM ENVELOPE FOR ALL MODES

BRANCH SIZE		A		A1		B		B1		C		C1		D		D1		E		E1		F		F1	
mm	inch	mm	inch	mm	inch	mm	inch	mm	inch	mm	inch	mm	inch	mm	inch	mm	inch	mm	inch	mm	inch	mm	inch	mm	inch
DN40	1.50	163.2	6.43	120.0	4.72	204.2	8.04	140.0	5.51	230.2	9.06	155.0	6.10	229.2	9.02	123.0	4.84	316.2	12.45	136.0	5.35	280.2	11.03	103.8	4.09

The information on this sheet is Private and Confidential and is the property of Crane Process Flow Technologies Limited and must not be published directly or indirectly in any manner whatsoever without the written permission of the Company and must not be used in any way detrimental to their interests.  
© Crane Process Flow Technologies

**CRANE** Process Flow Technologies  
A Crane Co. Company

**Saunders**  
The Science Inside

Title  
SCHEDULE OF LEADING DIMENSIONS FOR DN40/1.50  
WEIR 'T' BODY WITH MAINLINE BUTT WELD ISO 1127 S1  
ENDS, BRANCH HYGIENIC CLAMP END WITH ISO 1127 S1 BORE.  
FITTED WITH TOPWORKS OPTIONS

Drawn RI Date 09.05.17 UNCONTROLLED IN  
Checked RND Date 09.05.17 HARD COPY FORMAT

First Angle Projection Method E DO NOT SCALE Drawing No. WEB-086-ASSY Issue. 1